

WE OFFER

- Standard Chemical Feed Systems
- Controls / Controllers
- Metering Pumps
- Custom Engineered Systems
- On-Site Oxidant Generation
- Polymer Feed Systems
- Chemical Storage & Accessories
- Booster Skids
- Performance Monitoring Tools
- Transfer Pumps
- Level Monitoring
- Web Based Remote Monitoring
- Instrumentation
- Flow Measurement
- Innovative Accessories

SPECIALIZED SERVICES

- System Installations
- Start Up & Commissioning
- Contract Maintenance
- Emergency Repairs
- Plant Audits / System Surveys
- Pump/ Accessory Repairs
- Equipment Pool Management
- Equipment Rentals
- Controller Maintenance & Repair

MARKETS SERVED

- Industrial
- Municipal
- Commercial
- Recreational

1364 Hamilton Parkway

Itasca, Illinois 60143

Toll Free 888-200-1800

Phone: 630-351-9070

Fax: 630-351-9080

www.equip-solutions.com

Tempest Liquid Polymer Feed & Control Station



- Motorless, Multi-Stage Mixing
- Hydro-Kinetic Disperser
- EZ View Mixing Chamber
- Choice of Pump Type
- Choice of Pump Manufacturer
- Touch Pad Microprocessor
- Polymer Paced to Water Flow
- Local and Remote Operation
- Water Flow Readout
- Concentration Set-Point
- Remote 4-20 mA Control
- Feed Rate Calibration
- Adjustable Flushing Cycle
- On-Board Post Dilution

The Tempest Series of liquid polymer feed and control stations are designed to provide maximized polymer performance without the hassles and headaches these applications cause for water treatment professionals.

The system design provides the right type of mixing energy at the critical moment of initial wetting and tapers that energy through a multi-stage regime of hydrating zones. The net result is a fully hydrated polymer solution with maximum charge site exposure which assures optimized polymer usage and performance. The design eliminates unwanted agglomerations, plugging and the costly mess of dealing with these issues.

The unit operation is simple. The user enters the desired polymer concentration and selects manual or automatic operation. Primary dilution water flow is controlled by a solenoid valve which allows water to enter the unit.

Primary dilution water flow rate data is measured continuously to assure that adequate flow is present and fed back to the Tempest controller. Using calculations derived from the calibration stage, the unit automatically adjusts the polymer pump output to achieve the desired concentration.

Under conditions of high or low concentration, a loss of water flow or polymer feed (optional) the system automatically shuts down and notifies with an alarm. Each feed cycle is followed by an adjustable, multi-stage flush cycle to eliminate any plugging.

The system can be operated remotely via a 4-40mA or simple on/off signal.

Tempest Series Sizing Matrix

Model Number	Primary Dilution Water Range			Neat Polymer Range	
	Rated GPH	Min GPH	Max Inlet Pressure	Min GPH	Max GPH
TPS-60-D.4	60	6	100 PSI	0.04	0.40
TPS-60-D1	60	6	100 PSI	0.10	1.00
TPS-150-D.4	150	15	100 PSI	0.04	0.40
TPS-150-D1	150	15	100 PSI	0.10	1.00
TPS-150-D2.5	150	15	100 PSI	0.25	2.50
TPS-150-D4	150	15	100 PSI	0.40	4.00
TPS-300-D1	300	30	100 PSI	0.10	1.00
TPS-300-D2.5	300	30	100 PSI	0.25	2.50
TPS-300-D4	300	30	100 PSI	0.40	0.40
TPS-600-D2.5	600	60	100 PSI	0.25	2.50
TPS-600-D4	600	60	100 PSI	0.40	4.00
TPS-600-D8	600	60	75 PSI	0.80	8.00
TPS-1200-D4	1200	120	100 PSI	0.40	4.00
TPS-1200-D8	1200	120	75 PSI	0.80	8.00

Model Range	Connections			
	Water Inlet	Polymer Inlet	Solution Outlet	VAC
TPS 60-150-300 -600	1" FNPT	3/4" FNPT	1" FNPT	110
TPS 1200	1-1/2" FNPT	3/4" FNPT	1-1/2" FNPT	110

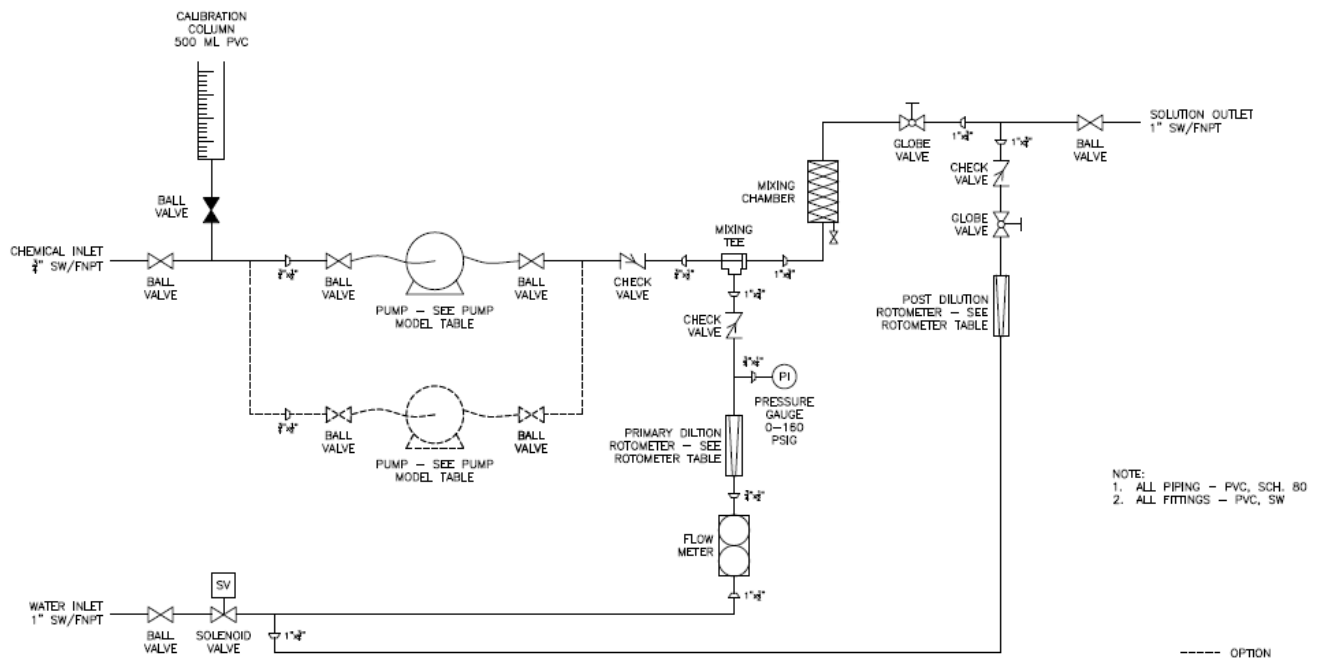

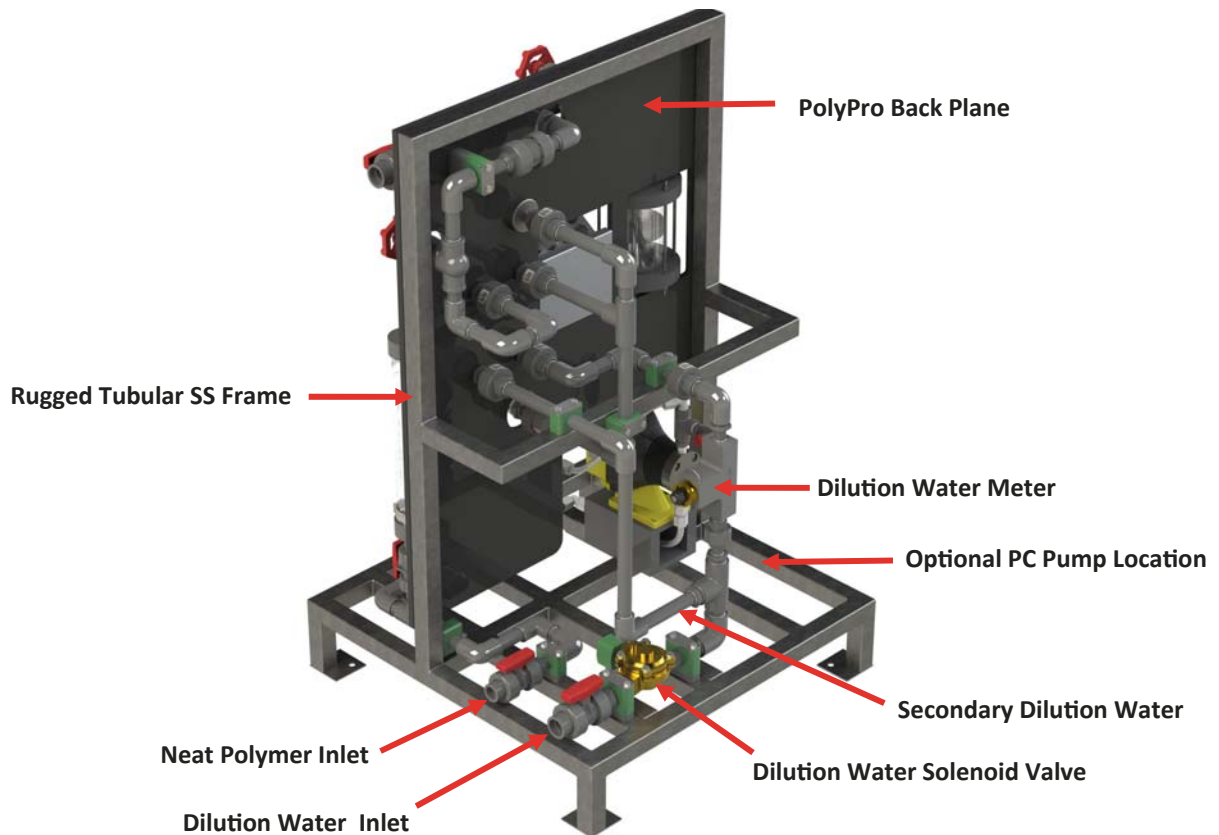
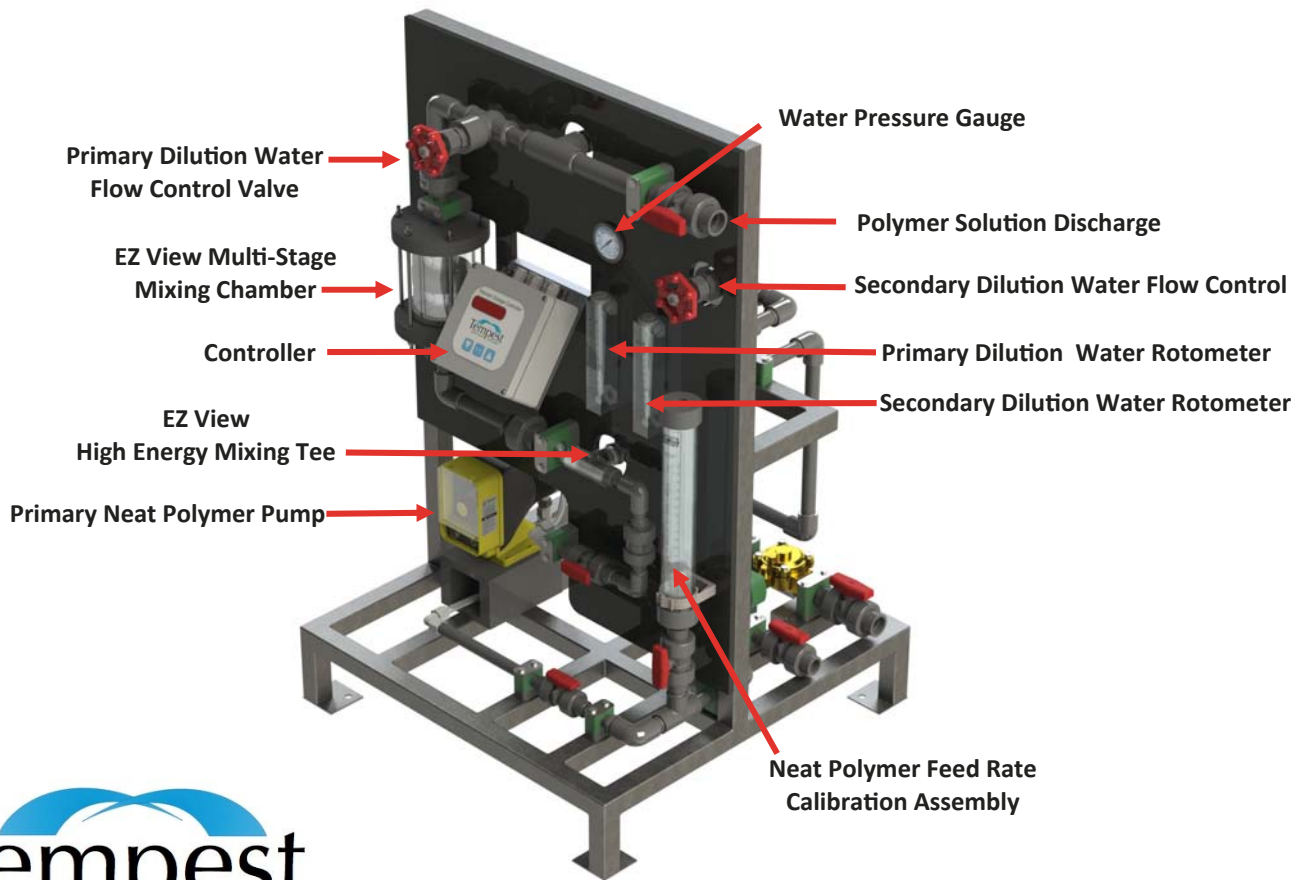

Tempest Features and General Specifications

- Flexible design permits the choice of type of neat pump and choice of pump manufacturer.
- Options for dual pump configuration for duty standby service.
- Open architecture provided easy access to all components for easy maintenance.
- Multiple Stage mixing optimizes hydration and activation.
- Controller calculates and holds solution concentration.
- Neat polymer pump is paced to dilution water flow for consistent solution concentration.
- Controller limits the ability to make too high or too low a solution protect against process upsets and gelling up the blending system.
- Low/no water condition shuts down system and raises alarm.
- System has selectable flushing cycle to clean polymer check valve and mixing tee, keeping the check valve free of agglomerations.
- Local or remote feed rate control.
- Local or remote solution concentration control.
- Modular design allowing you to select the system that best fits your current needs while protecting your investment by allowing field upgrades to enhance control or increase system output.
- Controller provides water flow and concentration set point readout.
- Touchpad controller makes mode selection simple with concise, easy to use menu.

- ◆ *Innovative*
- ◆ *Economical*
- ◆ *Flexible*
- ◆ *Reliable*
- ◆ *Rugged*

Wetted Materials:

- Water : PVC, brass, bronze, buna N, Acrylic, 316 SS
- Polymer: PVC, Acrylic, PTFE, PP, 316 SS

Electrical

- 110 VAC Single Phase 60 Hz

Controls

- Touchpad with 3 Line LCD Display
- Manual Start/Stop
- Remote Local

Inputs

- Relay: Remote Start
- 4-20 mA Pump Speed

Outputs

- Contact closure: General Alarm
- Contact closure: System Running

