

NextStep dosing pumps are designed for high resolution metering control and reliability and cover a wide range of applications. The advanced microprocessor driven stepper motor allows for digital control of both the discharge stroke and the suction stroke duration evenly distributing the chemical into the process. This wide range of control and reduced pulsation allows for reliable metering of off gassing and viscous chemicals with extremely high accuracy. NextStep pumps are even backed by a five-year warranty that includes the diaphragm.

Programming is simplified using a dial knob interface and intuitive symbols and prompts. A large easy to read multi-color backlit display indicates pump status with four different backlight colors. With multiple operating modes to choose from, the operator can precisely set the flow rate required by the application and easily read it directly in GPH, LPH and % on the graphic display.

FEATURES

3,333:1 TURNDOWN RATIO

- Produces a nearly constant chemical discharge
- 100% to 0.1% capacity control
- Suction stroke duration is adjustable from 100% to 30%

MULTIPLE OPERATING MODES

- Proportional control
 - by a 0/4-20mA input or 0-10 VDC signal
 - by pulse input, controlled based on a PPM setpoint, % setpoint or Oz/Pulse, or the flow rate of the pump in GPH/LPH
- Batch control by dry contact signal or manual activation
- Start-pause control based on a cycle time
- Daily and weekly timer
- Constant output mode

INPUTS

- Low tank level with alarm and warning indicator
- Water meter pulse input
- Stand-by mode input
- Dry contact input for remote start or stop
- 0/4-20mA or 0-10 VDC input

OUTPUTS

- Alarm relay (Selectable alarms)
 - Selectable as N.C. or N.O.: Level, Stand by, Overflow, High Temperature, No input, Overpressure
- 4-20mA output

LIQUID END CONSTRUCTION

- PVDF Head with integrated bleed valve
- Double check valves
- Solid PTFE diaphragm with a 5-year warranty

ACCESSORIES INCLUDED

- PVDF injection valve
- Foot valve strainer with integrated low tank level switch
- Suction, discharge and bleed return tubing
- Input and output cables

Operating messages are easily recognizable by different background colors of the display:



White: StandBy
Green: Working

Yellow: Warning (low level tank)
Red: System Alarm

PULSAFEEDER[®]



INTERFACE

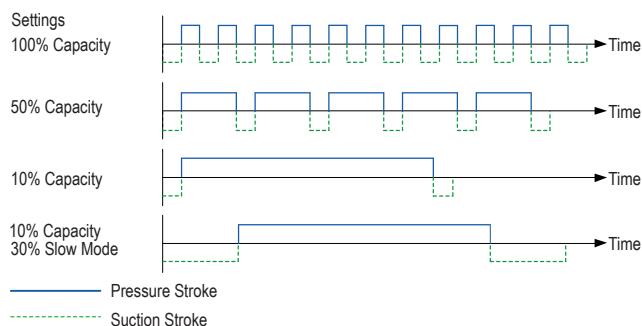

SPECIFICATIONS

MODEL	NS1	NS2	NS3	NS4	NS5	NS6	NS7	NS8	NS9
Flow GPH	0.5	1.3	2	3.4	5.3	7.4	13.2	18.4	21.1
Pressure Max PSI	362	290	232	145	101	72	58	43	29
Pump Head Material	PVDF								
Diaphragm	PTFE								
O-Rings and Valve Seats (Check Balls)	FKM B, EPDM (Ceramic or PTFE)								
Liquid-Ends (S/D) Tubing Size	3/8" O.D.					1/2" O.D.			
Injection Valve	1/2" MNPT							3/4" MNPT	
Capacity Control	100% to 0.1%								
Slow Mode	From 100% to 30%								
Viscosity	100 CPS @ 100% Slow Mode 1,000 CPS @ 30% Slow Mode								
Input Pulses	Max. 24VDC, Max. 50mA								
Input Pulses (Hall Effect)	Max. 12VDC, Max. 50mA, with +12V output								
Input Analog	0/4 - 20mA 0 - 10V (Max Load 500 Ω)								
Outputs Alarm	Dry Contact Relay N.O./C/N.C. Max Load 250 VAC, 2A								
Level Connection	12VDC, Max. 50mA								
Protection	IP65 Humidity 85% and T ≤ 104°F, 40°C 70% and T = 86°F, 50°C (Non-Condensing)								
Pump Housing	PP Plastic Reinforced With Glass Fiber								
Operating Temperature °F	33.8 - 113°F								
Transport and Storage Temperature °F	14 - 122°F								
Power Supply	90 - 240 VAC, 50/60 Hz								
Energy Consumption	30W								
Communication	RS485 / Modbus RTU (Optional)								
Audible Noise	52.8 dB (Equivalent Continuous Level Of "A" Weighted Sound Pressure)								
Repeatability	± 1%								
Net Weight	6 lbs. (With "PVDF" Pump Head)								

DIMENSIONS

NextStep NS1, NS2, NS4

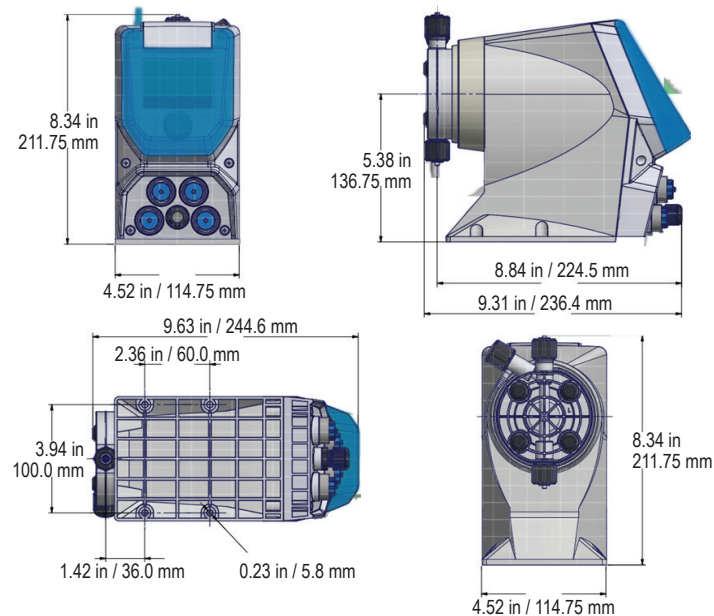

DIMENSIONS

NextStep NS3, NS5 thru NS9

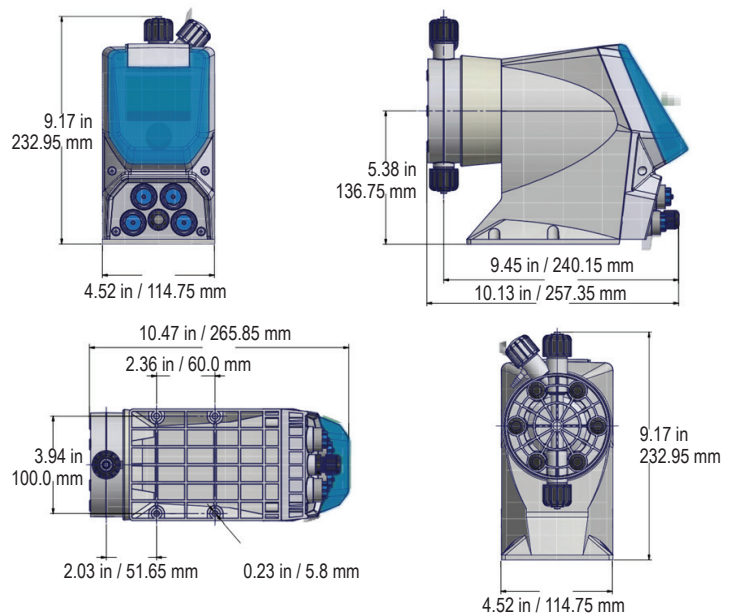

31 Presidential Drive
Roselle, IL 60172